

**For a Free Quote:**

Web: [EnergyPal.com/solar](http://EnergyPal.com/solar)

Call: 1-800-990-3725

Email: [contact@energypal.com](mailto:contact@energypal.com)

# EnergyPal

## **Solar Panel Guide Specification Data Sheet**

**Greenenergy Power  
GP-70-80 Mono  
GP-75**

Also available on the web at  
[EnergyPal.com/greenenergy-power-solar-panels/gp-75](http://EnergyPal.com/greenenergy-power-solar-panels/gp-75)

## MONOCRYSTALLINE SILICON MODULE

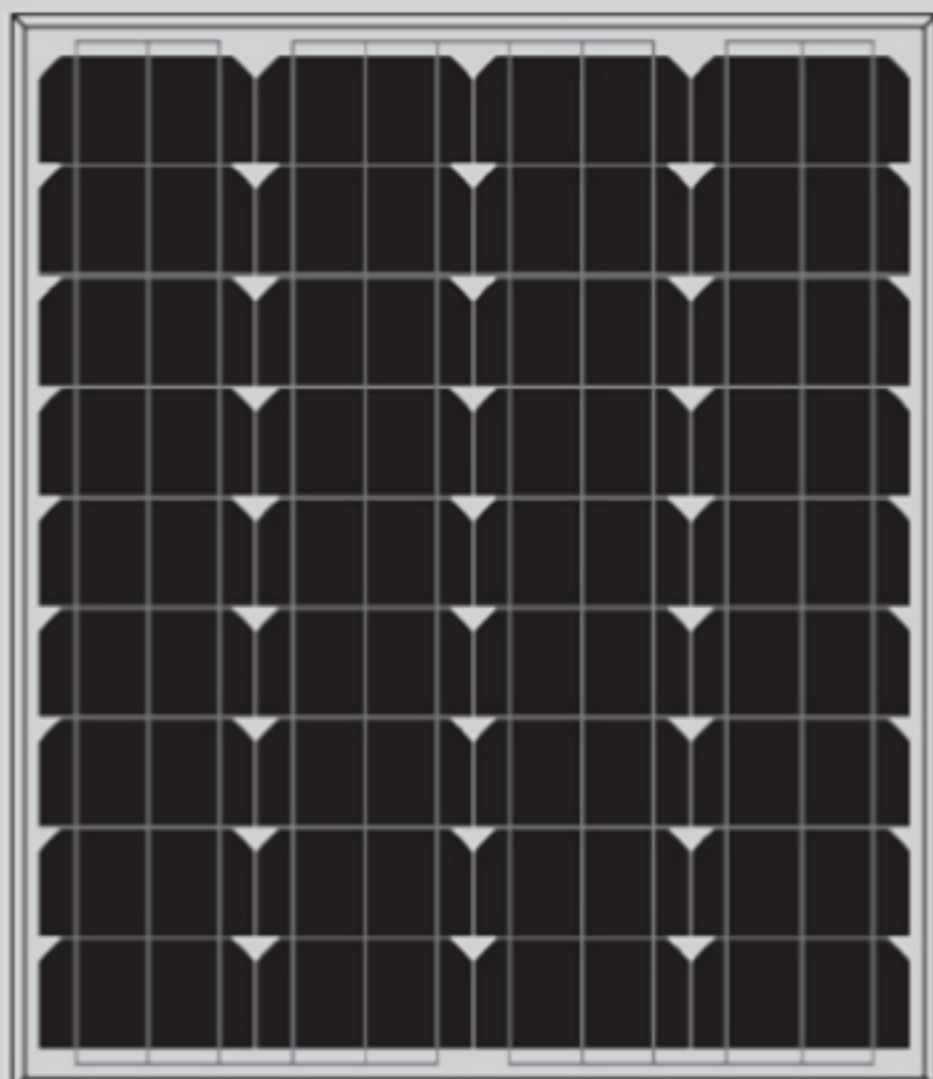

GREENERGY POWER  
SOLAR TECHNOLOGY

# GP-70 GP-75 GP-80

## MONOCRYSTALLINE SILICON MODULE

### Products Characteristics



Widely using of the most popular and mature type of modules for off-grid system.



Leading manufacturing technology in PV industry, strictly controlling the quality of raw materials and the process of producing



100% EL inspection, ensures modules are defects free.



Cells binned by current to improve module performance



Anti reflective glass. Not only to increase the light absorption, but also to make the module has the function of self-cleaning in water environment, effectively reducing the power loss caused by dust.



Outstanding performance in low-light irradiance environments.



Excellent mechanical load resistance: Certified to withstand high wind loads(2400pa) and snow loads(5400pa).



High salt and ammonia resistance



Positive power tolerance: 0~+5w

### Warranty

- 5 years product warranty
- 10-years 90% of Min. rated output power, and 25-years 80% of Min. rated output power warranty



# GP-70 GP-75 GP-80



**GREENERGY POWER**  
SOLAR TECHNOLOGY

Engineering Drawings (Front Side)

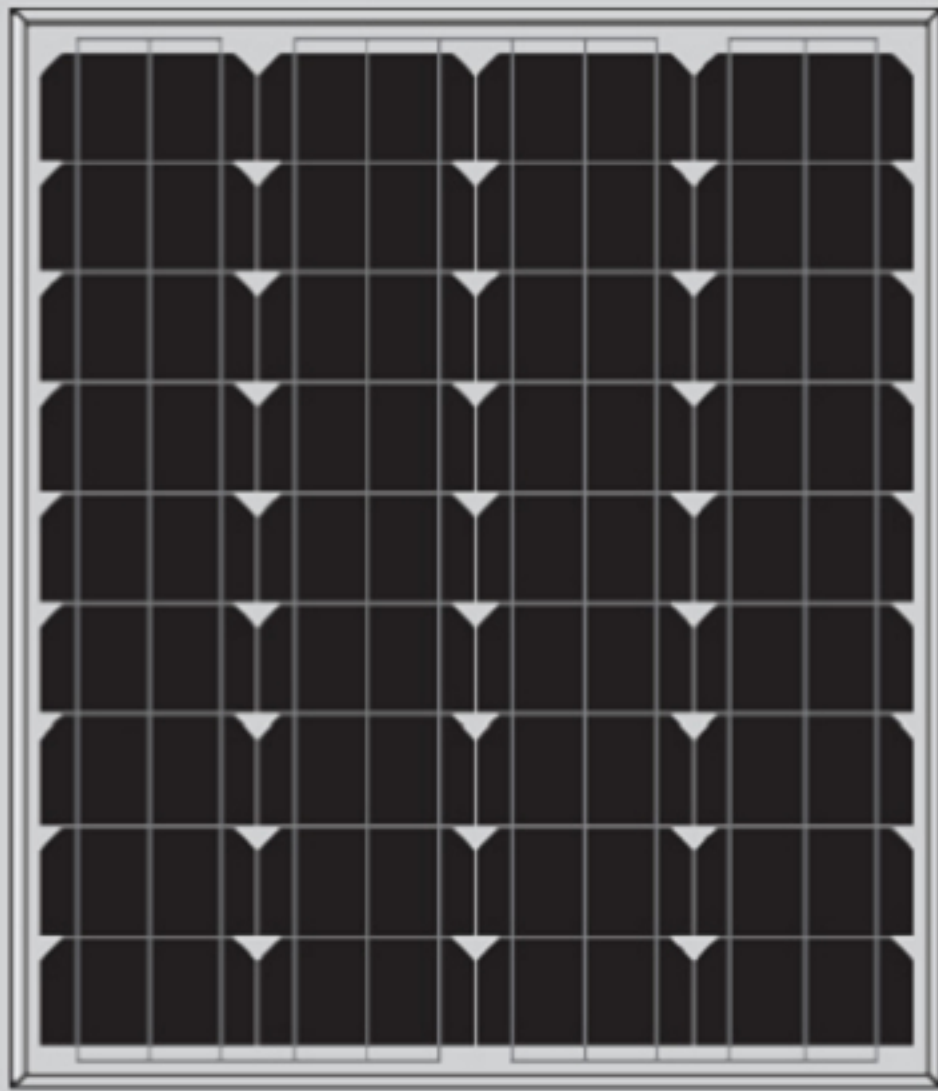

Engineering Drawings (Back Side)

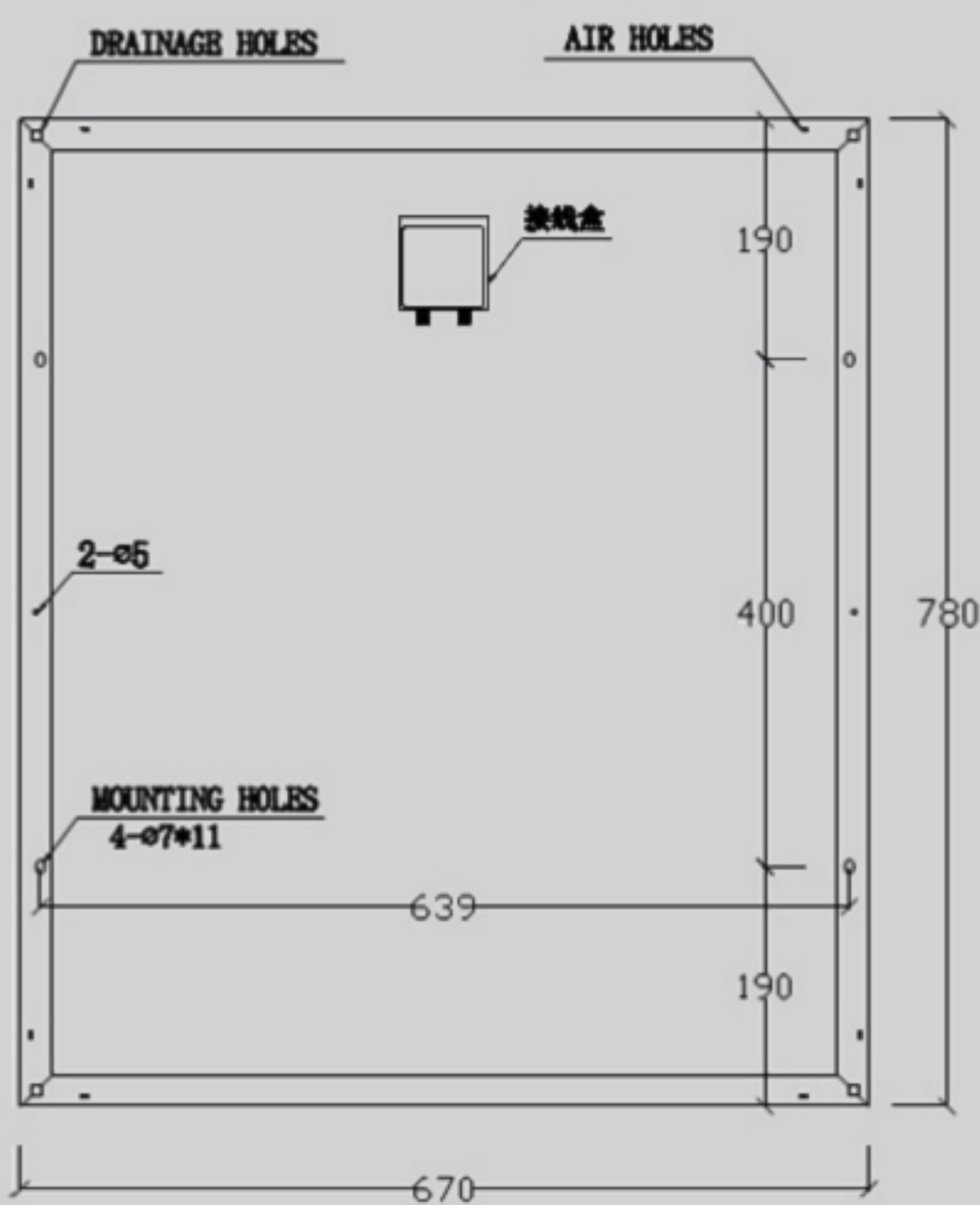

## Raw materials and Mechanical Parameters

	GP-70	GP-75	GP-80
Type of Cells(mm)	mono156×78/156×39		
NO. of Cells and Connections	4×9=36/4×18=72		
Dimensions(mm)(L*W*H)	780×670×30		
Weight(kg)	5.9		
Glass	3.2mm Tempered Glass		
Encapsulation	EVA		
Backsheet	Multilayer Composite		
Aluminium-Frame	Silvery/Black Anodized aluminium alloy		
Junction-Box	IP65/IP67		
Cable	NA, but customized is acceptable		
Connector	NA, but MC4 and MC4 Compatible are acceptable		
Package Configuration	6pcs/ctn		

## Performance Parameters

	GP-70	GP-75	GP-80
Maximum System Voltage	700V		
Operating Temperature	-45~+80°C		
Maximum Series Fuse	10A		
Maximum Static Load, Front Side (e.x. Snow, Wind)	5400Pa		
Maximum Static Load, Back Side (e.x. Wind)	2400Pa		
Application Grade	Class A		

## Electrical Parameters (Standard Test Condition)

	GP-70	GP-75	GP-80
Rated Maximum Power(Mp)	70W	75W	80W
Power Tolerance	0~+5W		
Cell Efficiency	16.4%	17.6%	18.8%
Open Circuit Voltage(Voc)	22.2V	22.4V	22.6V
Maximum Power Voltage(Vmp)	17.2V	17.4V	17.6V
Short Circuit Current(Isc)	4.35A	4.61A	4.87A
Maximum Power Current(Imp)	4.07A	4.32A	4.55A
Temperature Coefficient of Isc	+0.06%		
Temperature Coefficient of Voc	-0.32%		
Temperature Coefficient of Pmp	-0.45%		
Standard Test Condition	Irradiance:1000W/M2, Cell Temperature:25°C, Spectrum AM:1.5		

The Electrical Parameters of the module are the average theory figure under the standard test condition, each one exists difference. Can not be treated as the basis of module delivery.