

For a Free Quote:

Web: EnergyPal.com/solar

Call: 1-800-990-3725

Email: contact@energypal.com

EnergyPal

Solar Panel Guide Specification Data Sheet

Ningbo Green Light Energy Technology Co., Ltd.

GS-70P

GS-70P

Also available on the web at
EnergyPal.com/ningbo-green-light-energy-technology-co-ltd-solar-panels/gs-70p

Photovoltaic Module

Polycrystalline

GS-70P



Quality and Safety

- *Rigorous quality control meeting the highest international standards
- *High-transmissivity low-iron tempered glass, strong aluminium frame Using UV-resistant silicon
- *IEC61215,IEC61730,Safety Class II,conformity to CE

Features

- *Aesthetic appearance with excellent efficiency based on innovative photovoltaic technologies
- *High quality,strong aluminium frame,passing mechanical load testing 5400 Pa and wind pressure 2400Pa

Warranties

- *10 years limited product warranty
- *15 years at90% of the minimal rated power output
- *25 years at80% of the minimal rated power output

Certificates



Electrical Characteristics

Model	GS-70P6
Maximum Power at STC (P _{max})	70W
Optimum Operating Voltage (V _{mp})	17.6V
Optimum Operating Current (I _{mp})	3.980A
Open-Circuit Voltage (V _{oc})	21.80V
Short-Circuit Current (I _{sc})	4.340A
Solar Cell Efficiency (%)	16.20
Solar Module Efficiency (%)	13.50
Operating Temperature	-40to85°C
Maximum System Voltage	DC1000
Maximum Series Fuse Rating	15A
Power Tolerance	+/-3%
STC:Irradiance 1000W/m ² ,Modules Temperature 25°C,AM=1.5	



GREEN SOLAR

Engineering Drawings

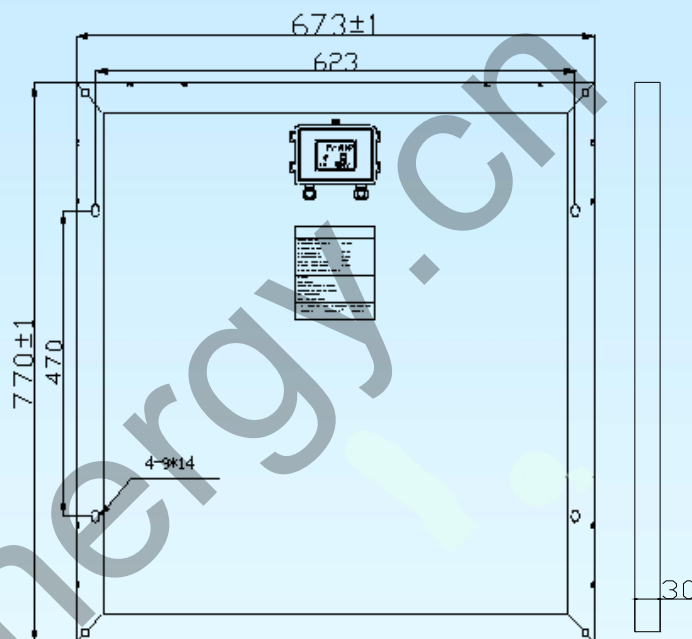
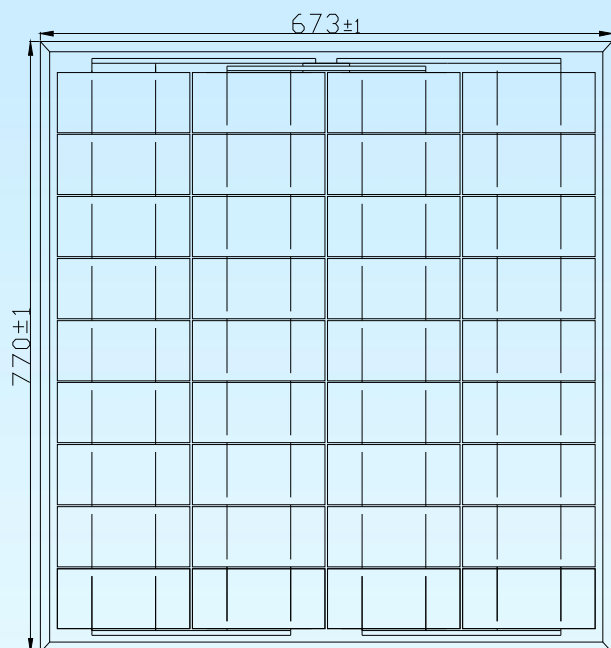

Mechanical Characteristics

Solar cell	Poly-Crystalline 156*78mm
No. of cells	36(4*9)
Dimensions	770mm*673mm*30mm
Weight	6.2kg
Front glass	3.2mm tempered glass
Frame	Anodized aluminium alloy
Junction box	PV-LH0808
Connector	/
Output cables	/
1*20'	/
1*40'	/
1*40'HQ	/

IV-Curves

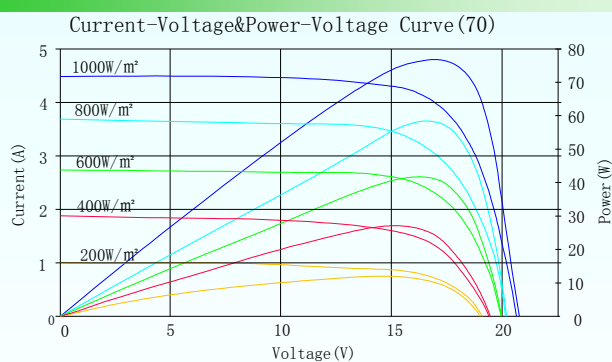

Temperature Coefficient

Nominal Operating Cell Temperature (NOCT)	47°C ± 2°C
Temperature Coefficient of Pmax	-0.47%/K
Temperature Coefficient of VOC	-0.351%/K
Temperature Coefficient of ISC	+0.035%/K