

For a Free Quote:

Web: **EnergyPal.com/solar**

Call: **1-800-990-3725**

Email: **contact@energypal.com**

EnergyPal

Solar Panel Guide Specification Data Sheet

**Phono Solar Technology Co., Ltd.
MWT Mono/290-305
PS290M-20/UM**

Also available on the web at
EnergyPal.com/phono-solar-technology-co-ltd-solar-panels/ps290m-20-um

Phono[®] Solar

MWT Module

Mono/290-305W

- 20W** **Higher Efficiency**
20W+ higher rated power more than common module
- 3%** **Higher Generation**
3% higher power generation on the same installation
- \$** **Lower Cost**
BOS cost can be reduced by 1.2-1.5 USD cent/w
- ◆** **Better reliability and Stability**
Lower degradation and higher generating capacity ensure better module performance
- ✚** **Wider Technical Compatibility**
MWT can be combined with most existing manufacturing process and technologies

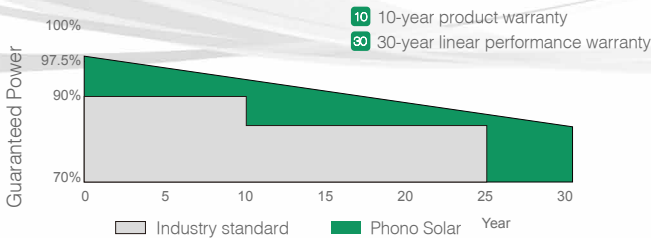

Bloomberg Tier1
NEW ENERGY FINANCE

TOP PERFORMER 2018
DNV-GL
PV MODULE RELIABILITY SCORECARD

TOP PERFORMER



EN EN-20180815

SINOMACH | SUMEC
SUMEC GROUP CORPORATION

ELECTRICAL TYPICAL VALUES

Model	PS290M-20/UM	PS295M-20/UM	PS300M-20/UM	PS305M-20/UM
Type	Monocrystalline 6 inch x 6 inch square, 6 × 10 pieces in series			
Rated Power (Pmpp)	290W	295W	300W	305W
Tolerance	0~+5w			
Rated Current (Impp)	9.07	9.17	9.26	9.36
Rated Voltage (Vmpp)	32.00	32.20	32.40	32.60
Short Circuit Current (Isc)	9.58	9.67	9.76	9.85
Open Circuit Voltage (Voc)	39.00	39.20	39.40	39.60
Module Efficiency (%)	17.83	18.13	18.44	18.75
NOCT (Nominal Operation Cell Temperature)	43±2°C			
Voltage Temperature Coefficient	-0.29%/°C			
Current Temperature Coefficient	+0.05%/°C			
Power Temperature Coefficient	-0.39%/°C			

MECHANICAL CHARACTERISTICS

Length	1640mm (64.57 inch)
Dimension (L x W x H)	Width: 992mm (39.06 inch) Height: 35mm (1.38 inch)
Weight	18.5kg (40.79 lb)
Front Glass	3.2mm toughened glass
Frame	Anodized aluminium alloy
Cable	4mm ² (IEC) , Length:900mm or Customized length
Junction Box	IP 67 rated

ABSOLUTE MAXIMUM RATING

Parameter	Values
Operating Temperature	From -40 to +85°C
Hail Diameter @ 80km/h	Up to 25mm
Surface Maximum Load Capacity	Up to 5400Pa
Maximum Series Fuse Rating	15A
IEC Application Class (IEC61730)	A
Fire Rating (IEC61730)	C
Module Fire Performance (UL 1703)	Type 1
Maximum System Voltage	DC 1000V (IEC)

PACKING CONFIGURATION

Container	20' GP	40' HQ
Pieces/Container	312	896

1. In compliance with our warranty terms and conditions.
2. Measurement conditions under irradiance level of Standard Test Conditions(STC): 1000W/m²
Air mass 1.5 Spectrum, cell temperature of 25°C.

ELECTRICAL CHARACTERISTICS

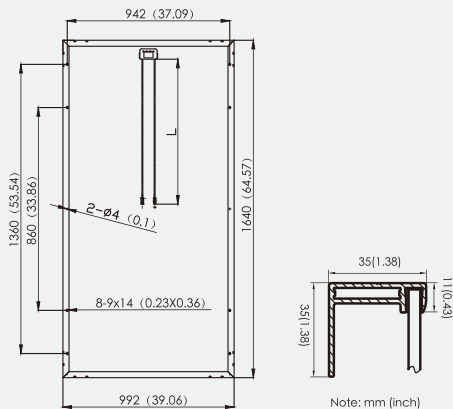
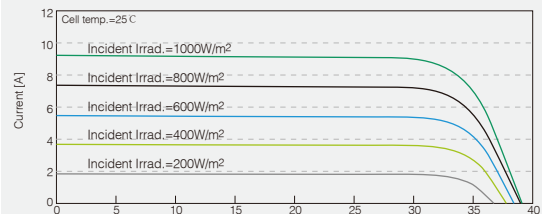
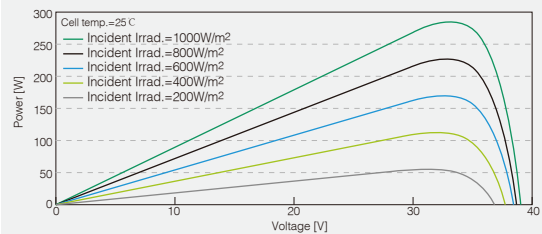

Phono[®] Solar

Note: This datasheet is not legally binding. Phono Solar Technology Co., Ltd. reserves the right to adjust specifications without notice. Further information please refer to our [Website:www.phonosolar.com](http://www.phonosolar.com), [E-mail:info@phonosolar.com](mailto:info@phonosolar.com)