

For a Free Quote:

Web: EnergyPal.com/solar

Call: 1-800-990-3725

Email: contact@energypal.com

EnergyPal

Solar Panel Guide Specification Data Sheet

Redarc Electronics Pty Ltd

SMR1150-SL

SMR1150-SL

Also available on the web at
EnergyPal.com/redarc-electronics-pty-ltd-solar-panels/smr1150-sl

THE POWER OF

REDARC®

SOLAR

Monocrystalline Solar Panels

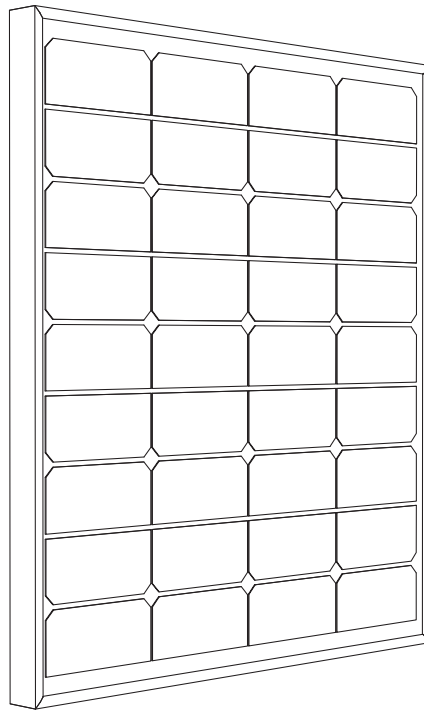

THE MONOCRYSTALLINE SOLAR PANEL

REDARC Monocrystalline Solar Panels are highly efficient with a robust design. A tempered glass coating and a sturdy double channel aluminium frame ensure that our panels will withstand harsh road conditions and extreme weather conditions.

Each panel is tested at time of manufacture to conform to CE standards, so you can be sure that the panel output is exactly as described in its specification.

WARNING & SAFETY INSTRUCTIONS

This appliance is not intended for use by persons (including children) with reduced physical, sensory or mental capabilities, or lack of experience and knowledge, unless they are supervised or have been instructed on how to use the appliance by a person responsible for their safety. Children should be supervised to ensure that they do not play with the appliance.

Do NOT use the Solar Panel to charge non-rechargeable batteries. Doing so may result in harm to the user and/or damage to the Regulator and/or Solar Panel. Only use the Solar Panel for charging Standard Lead Acid, Calcium content, Gel & AGM type 12V batteries.

All lead acid batteries produce harmful, explosive gases. The Battery should be mounted in a well ventilated area, as far as possible from any ignition sources. Do NOT smoke when in the vicinity of the battery under charge.

Battery acid is a harmful substance. Care should be taken when working with lead acid batteries, if the acid comes into contact with your eyes or skin, immediately wash the affected area with cold running water and seek medical assistance. Eye protection and gloves should be worn when handling lead acid batteries.

The Solar Panel will achieve best results when proper battery maintenance is regularly performed. This includes but is not limited to checking water and specific gravity levels of the battery.

Warning! Check the manufacturers data for your battery and ensure that the 'Absorption' voltage of the profile you select does not exceed the manufacturers recommended maximum charging voltage. If the 'Absorption' voltage for your battery type is too high, please select another charging profile.

CONTENTS

The Monocrystalline Solar Panel	1
Panel Features	2
50watt Monocrystalline Solar Panel	3
Specifications	3
80watt Monocrystalline Solar Panel	4
Specifications	4
120watt Monocrystalline Solar Panel	5
Specifications	5
150watt Monocrystalline Solar Panel	6
Specifications	6
150watt Monocrystalline SlimLine Solar Panel	7
Specifications	7
System Installation	8
Angle to the Sun	8
Aluminium Adjustable Mounts	9
ABS Plastic Mountings	10
System Wiring	13
Wiring Multiple Panels	13
Wiring Multiple Panels of Different Types	13
Standard BMS Installation	14
Wiring Precautions	15
Parallel and Series Connections	15
Accessories	16

PANEL FEATURES

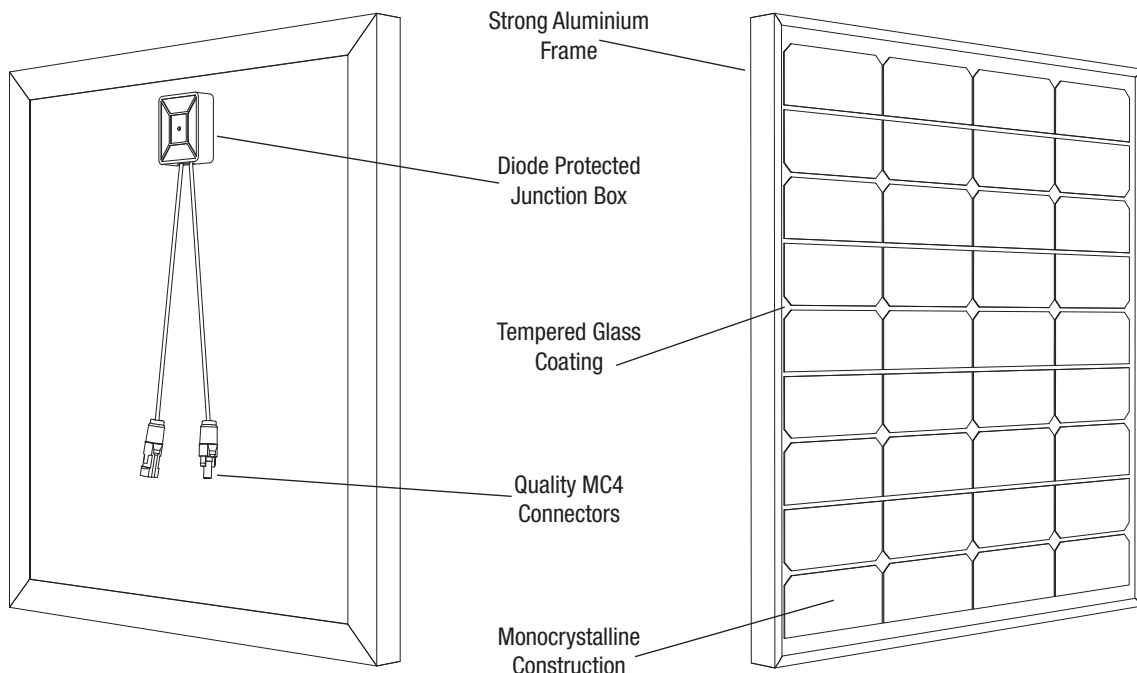

50WATT MONOCRYSTALLINE SOLAR PANEL

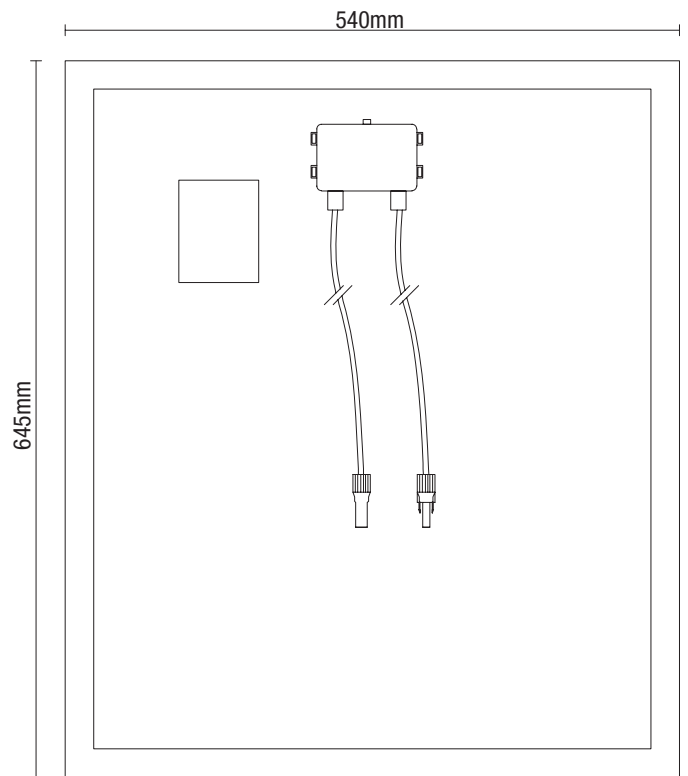
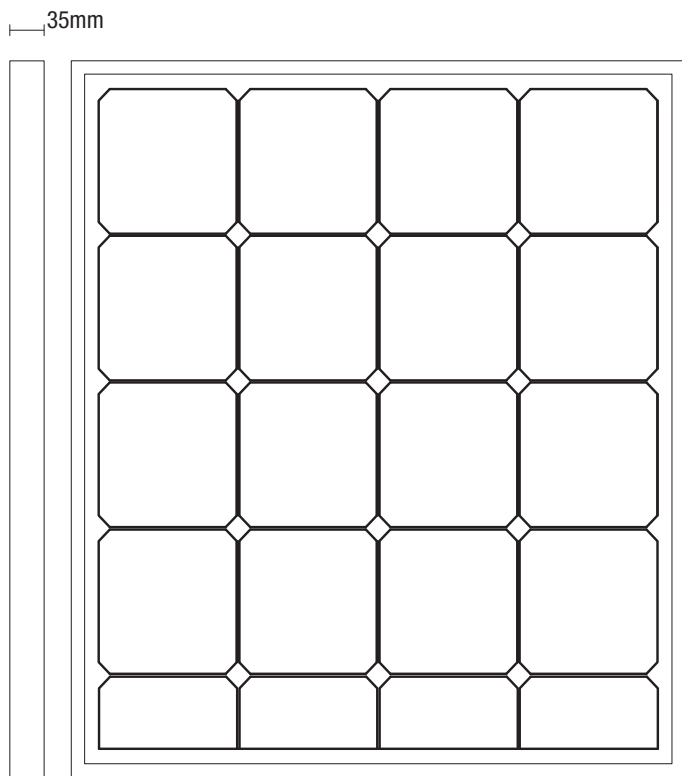

SPECIFICATIONS

Model	SMR1050	Short circuit Current	3.00A
Construction	Monocrystalline	Tolerance	±3%
Peak Power	50W	Frame	Anodized Aluminium
Net Weight	4.5kg	Cable length	750mm
Dimensions	645x540x35mm	Operating temp.	-40° to +85°C
Max power Voltage	18.00V	Std. test conditions	AM1.5 1000W/m ² 25°C
Max power Current	2.78A	Manufactured in	China
Open circuit Voltage	22.20V	Certification	CE

80WATT MONOCRYSTALLINE SOLAR PANEL

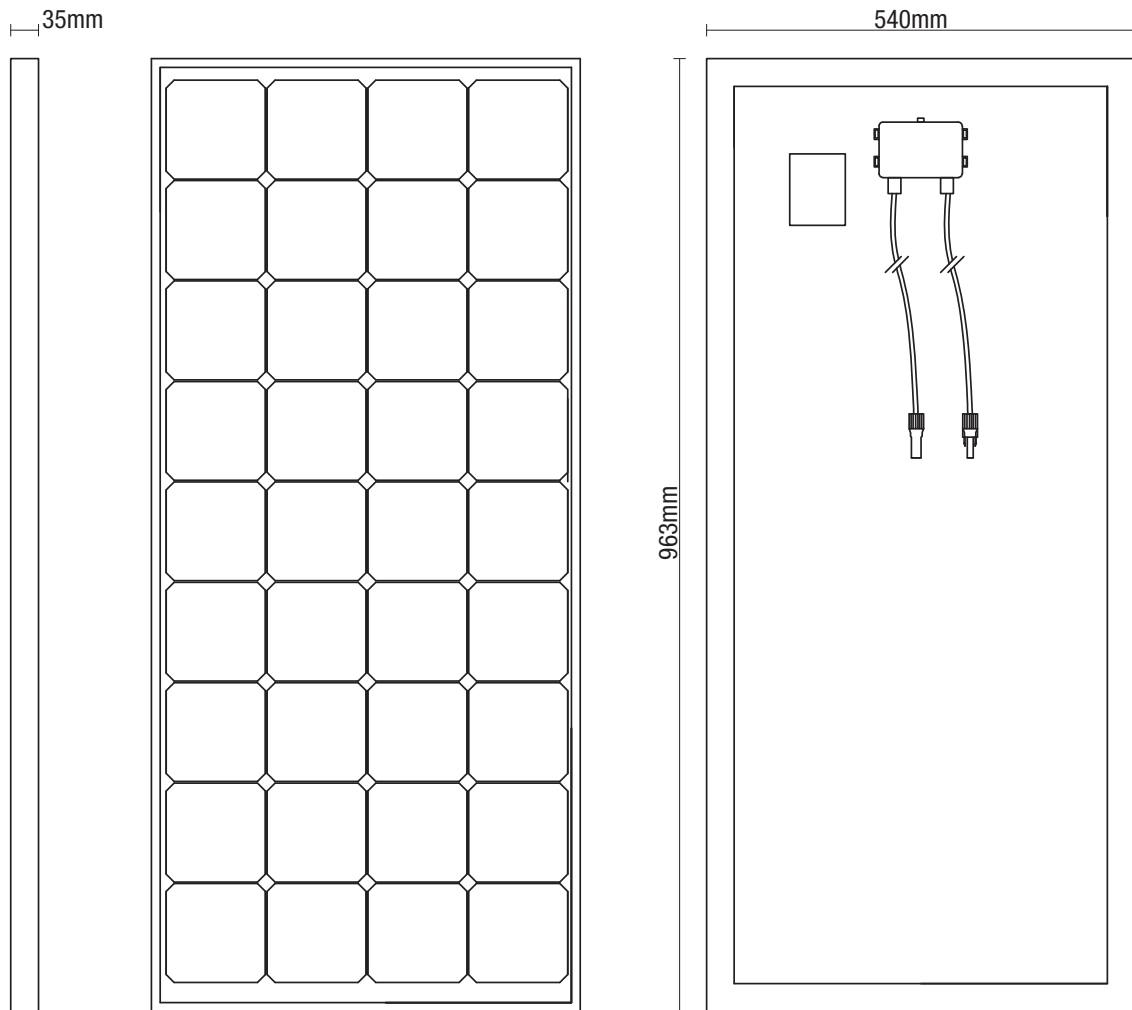

SPECIFICATIONS

Model	SMR1080	Short circuit Current	4.80A
Construction	Monocrystalline	Tolerance	±3%
Peak Power	80W	Frame	Anodized Aluminium
Net Weight	6.5kg	Cable length	800mm
Dimensions	963x540x35mm	Operating temp.	-40° to +85°C
Max power Voltage	18.00V	Std. test conditions	AM1.5 1000W/m ² 25°C
Max power Current	4.45A	Manufactured in	China
Open circuit Voltage	22.25V	Certification	CE

120WATT MONOCRYSTALLINE SOLAR PANEL

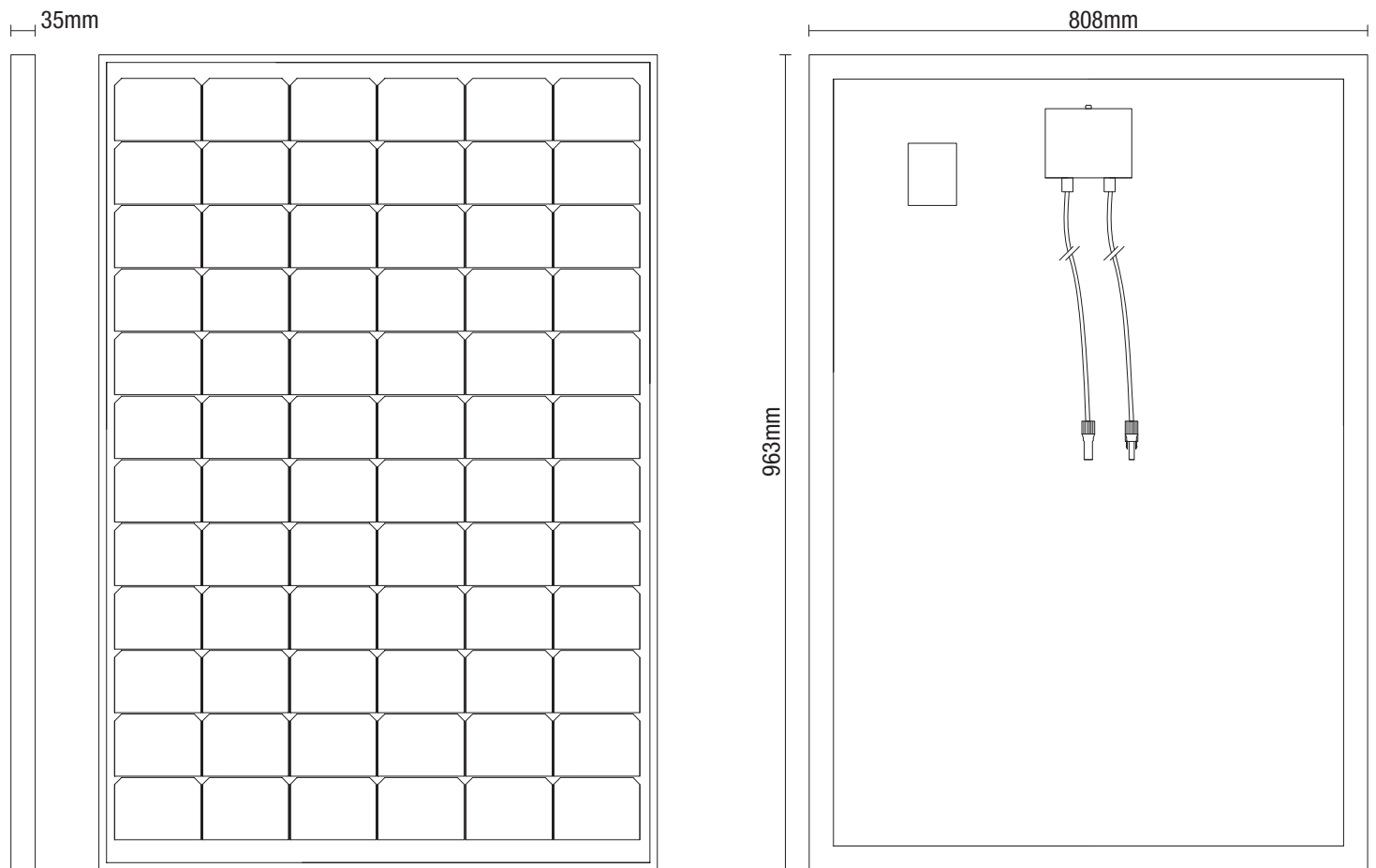

SPECIFICATIONS

Model	SMR1120	Short circuit Current	7.22A
Construction	Monocrystalline	Tolerance	±3%
Peak Power	120W	Frame	Anodized Aluminium
Net Weight	9.5kg	Cable length	800mm
Dimensions	963x808x35mm	Operating temp.	-40° to +85°C
Max power Voltage	18.50V	Std. test conditions	AM1.5 1000W/m ² 25°C
Max power Current	6.50A	Manufactured in	China
Open circuit Voltage	22.50V	Certification	CE

150WATT MONOCRYSTALLINE SOLAR PANEL

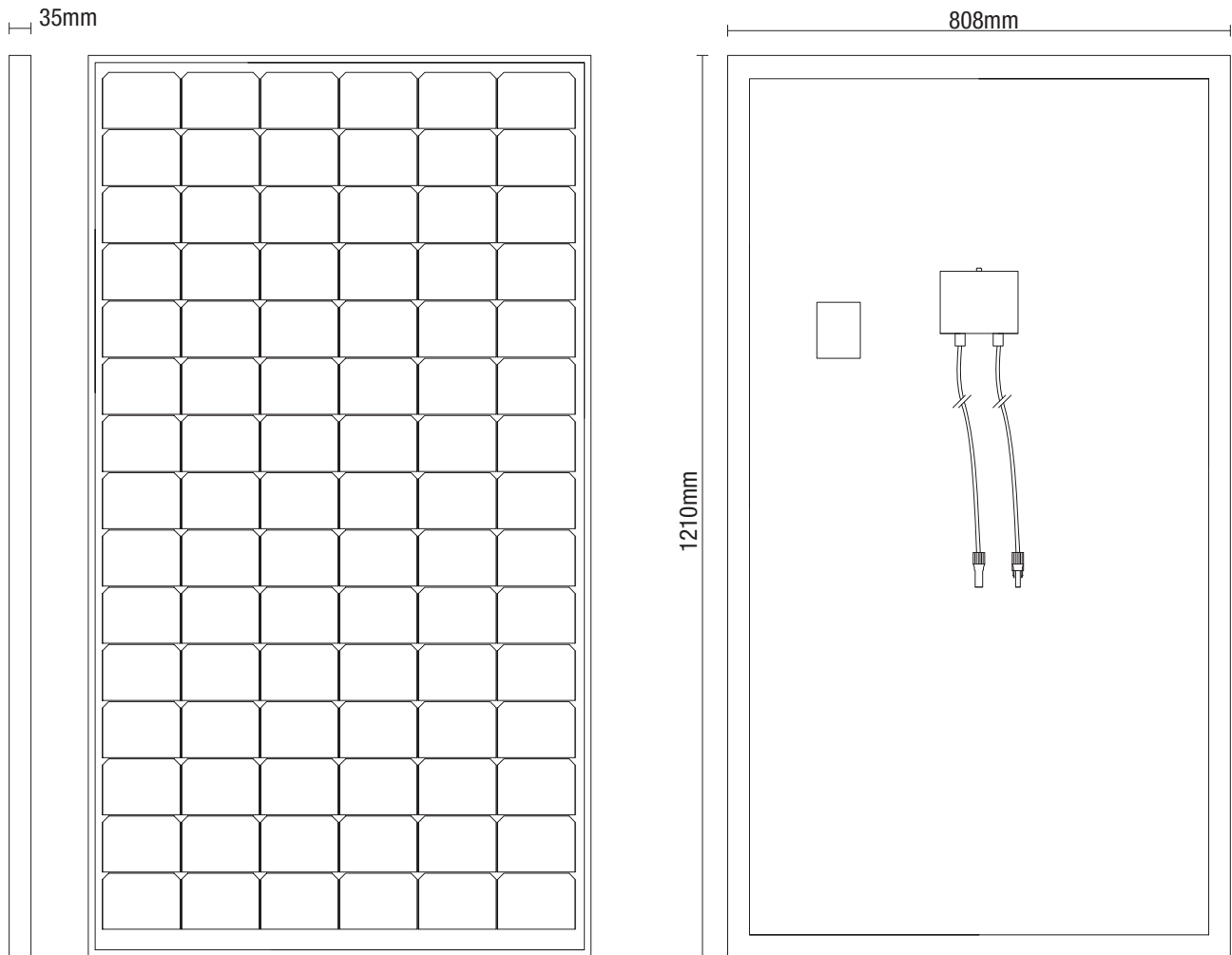

SPECIFICATIONS

Model	SMR1150	Short circuit Current	8.80A
Construction	Monocrystalline	Tolerance	±3%
Peak Power	150W	Frame	Anodized Aluminium
Net Weight	11.0kg	Cable length	800mm
Dimensions	1210x808x35mm	Operating temp.	-40° to +85°C
Max power Voltage	18.50V	Std. test conditions	AM1.5 1000W/m ² 25°C
Max power Current	8.11A	Manufactured in	China
Open circuit Voltage	22.50V	Certification	CE

150WATT MONOCRYSTALLINE SLIMLINE SOLAR PANEL

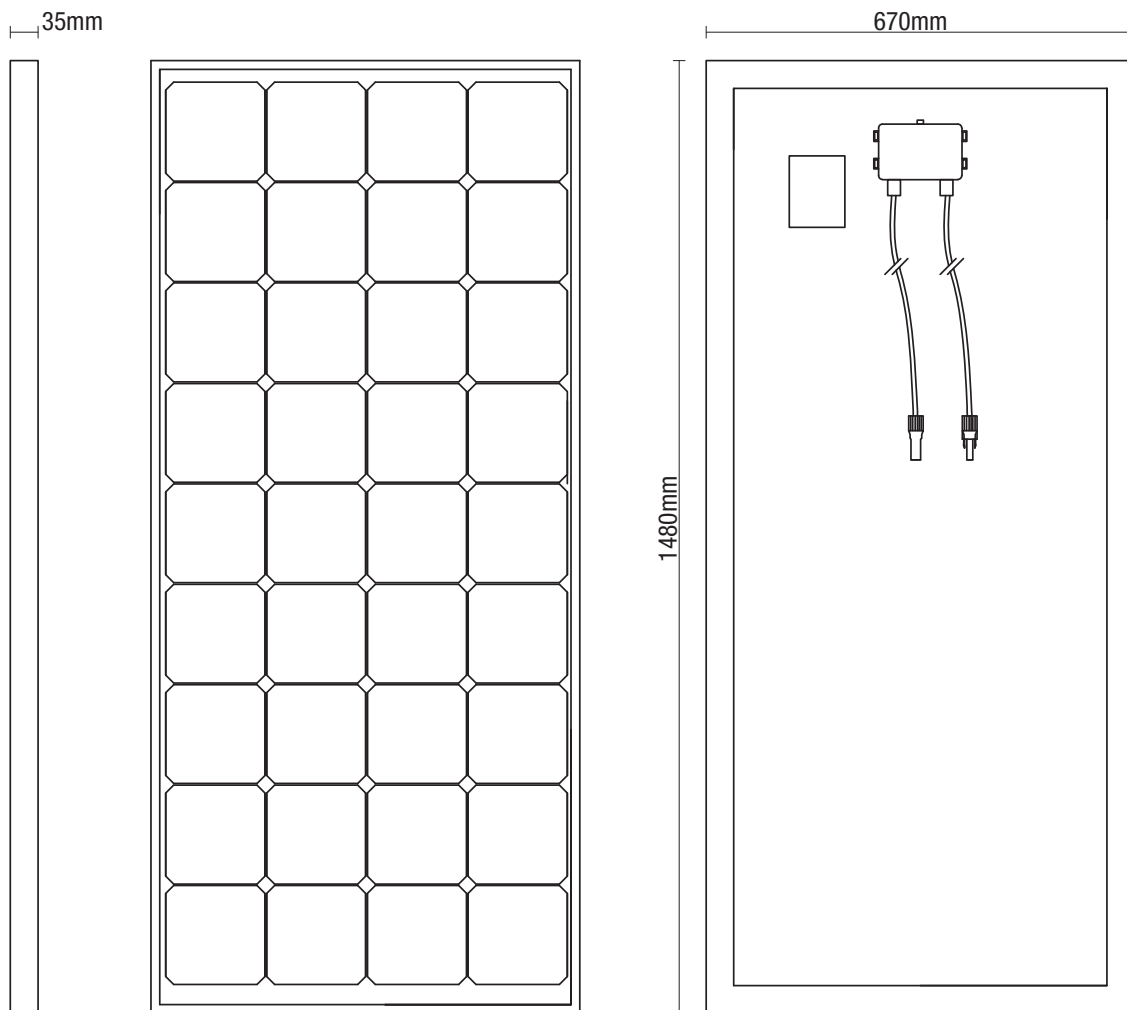

SPECIFICATIONS

Model	SMR1150-SL	Short circuit Current	9.00A
Construction	Monocrystalline	Tolerance	±3%
Peak Power	150W	Frame	Anodized Aluminium
Net Weight	12.0kg	Cable length	800mm
Dimensions	1480x670x35mm	Operating temp.	-40° to +85°C
Max power Voltage	18.40V	Std. test conditions	AM1.5 1000W/m ² 25°C
Max power Current	8.20A	Manufactured in	China
Open circuit Voltage	22.20V	Certification	CE

SYSTEM INSTALLATION

ANGLE TO THE SUN

REDARC solar panels will perform at their peak with the panel face angled directly towards the sun. In practice this is not always achievable, so REDARC recommend having your panels face NORTH at an angle of between 20° and 40° from the ground. This will ensure the best total output from your panel across the course of the day, no matter what season.

In the southern hemisphere, the sun is always in the NORTH half of our sky. As such facing your panel NORTH ensures the best angle to the sun for a fixed panel across the course of the day.

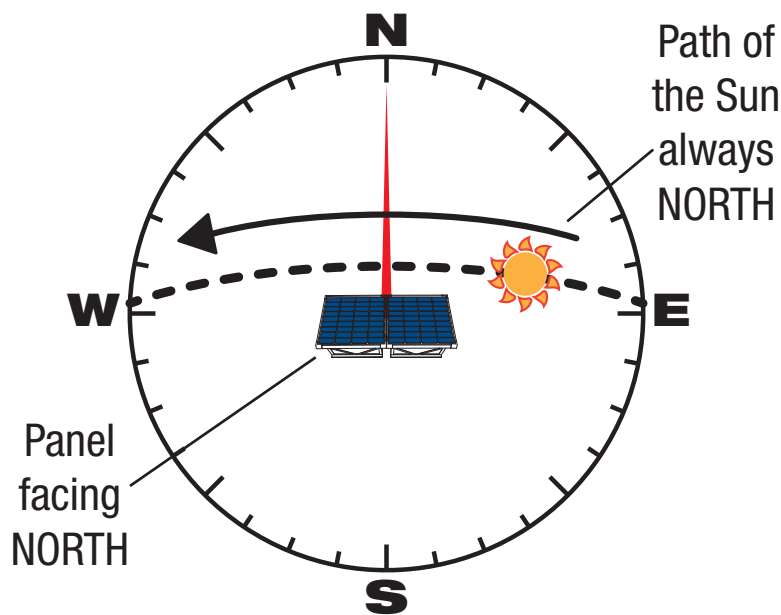

The optimal angle from ground of the panel is around 30° . Anywhere between 10° and 40° ensures good power generation across the course of the day.

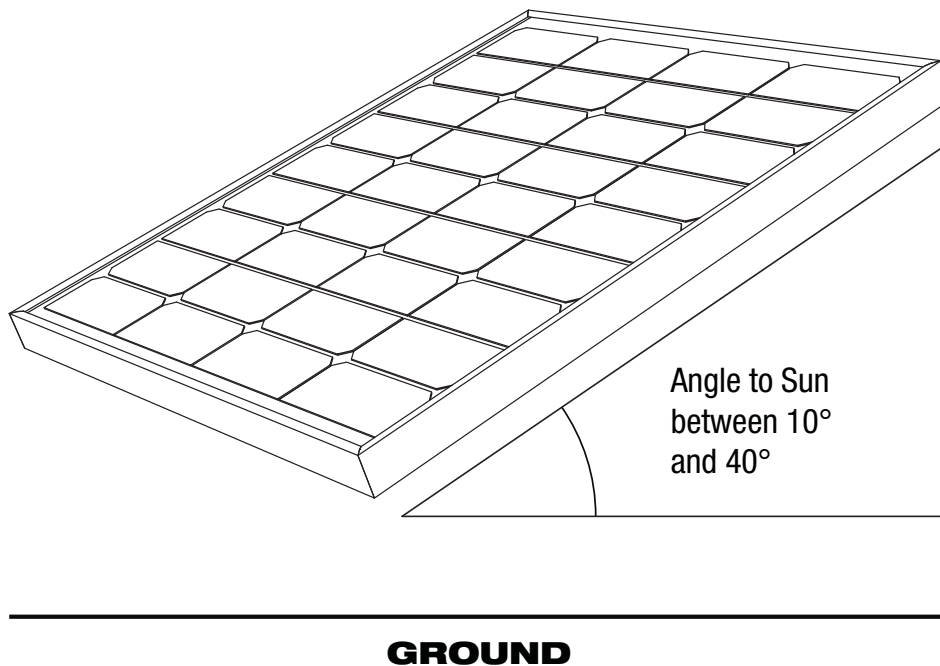

SYSTEM INSTALLATION

ALUMINIUM MOUNTS

Aluminium angled mounting kits are perfect for mounting solar panels to your Caravan or Camper-trailer. Aluminium mounting kits allow adjustment of the angle of the panel to the sun. The frame can be angled when camping and laid flat again ready for travel. Aluminium angled mounting kits are suitable for mounting panels to Camper-trailers or Caravans.

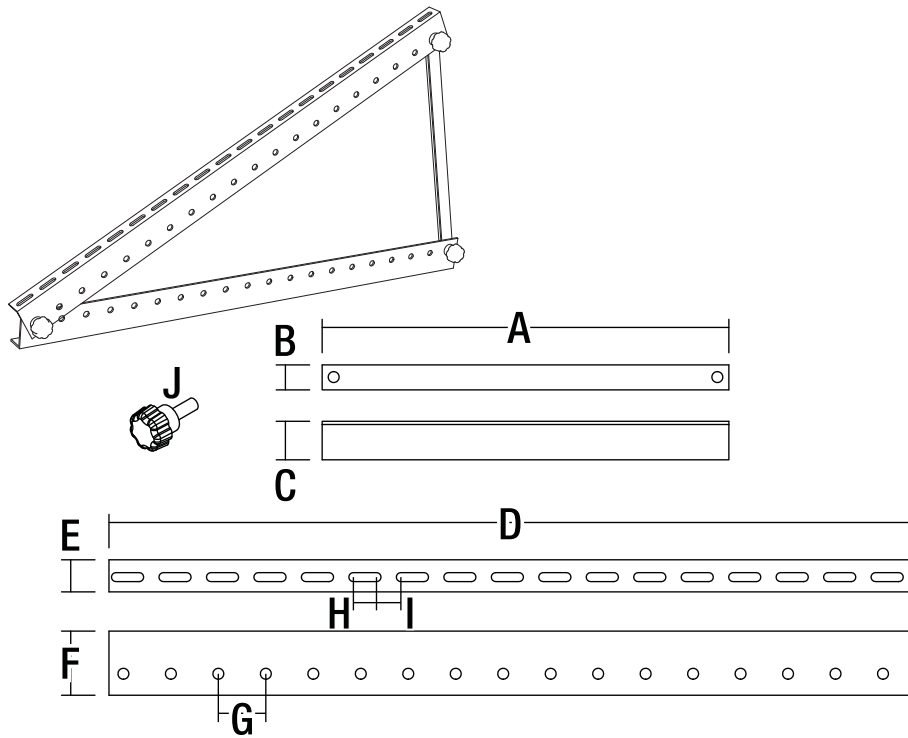

mm	SMI9004	SMI9005
A	26.5	37
B	20	20
C	30	30
D	518	712
E	23	23
F	50	50
G	39	39
H	20	20
I	20	20
J	x6	x6

ANGLE ADJUSTMENT

The angle of the panel to the sun is achieved by simply removing the threaded knob from the wingnut and replacing the knob in a mounting hole corresponding with the angle you require. See below for a visual representation.

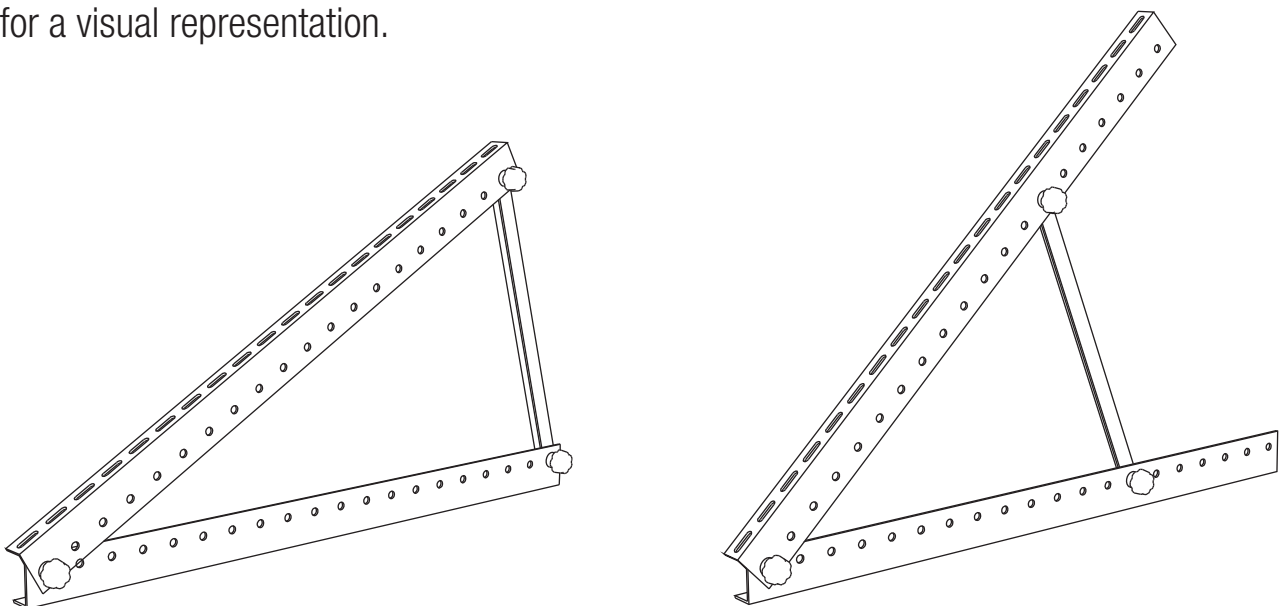

SYSTEM INSTALLATION

ABS PLASTIC MOUNTS

ABS Plastic Corner, Side and Spoiler mounts are designed to mount single or multiple panels to your RV or Caravan roof. The ABS plastic can be mounted using silicon adhesive, specifically designed adhesive tape or screw mounted. The panels are then mounted to the ABS plastic mounts using standard metal screws.

ABS Plastic spoiler mounts are designed to keep the wind resistance and resulting noise of your solar installation to a minimum.

INSTALLATION DIAGRAM

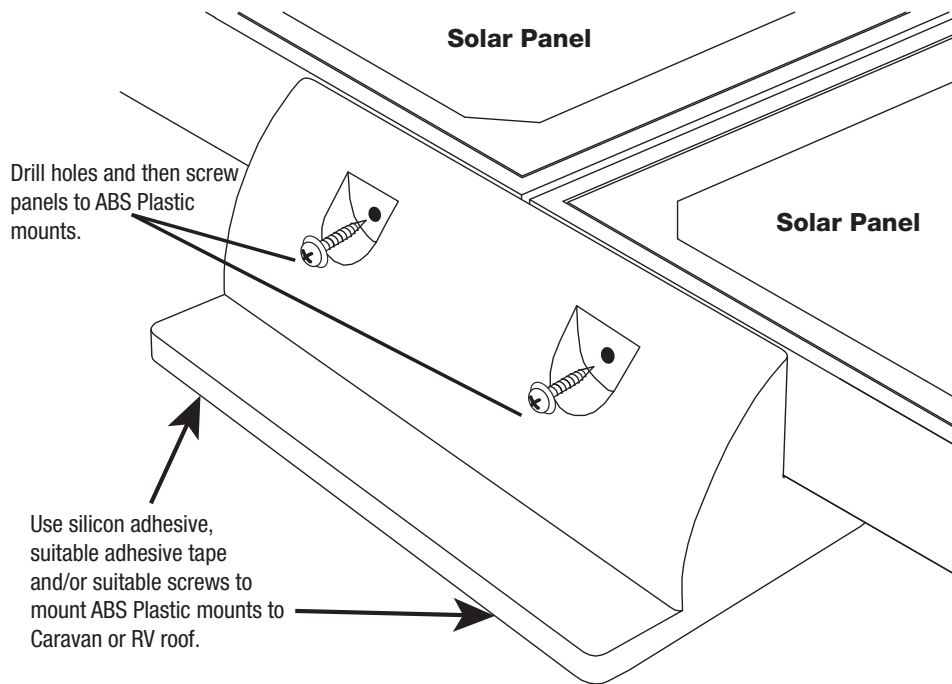

PROFILE DIMENSIONS

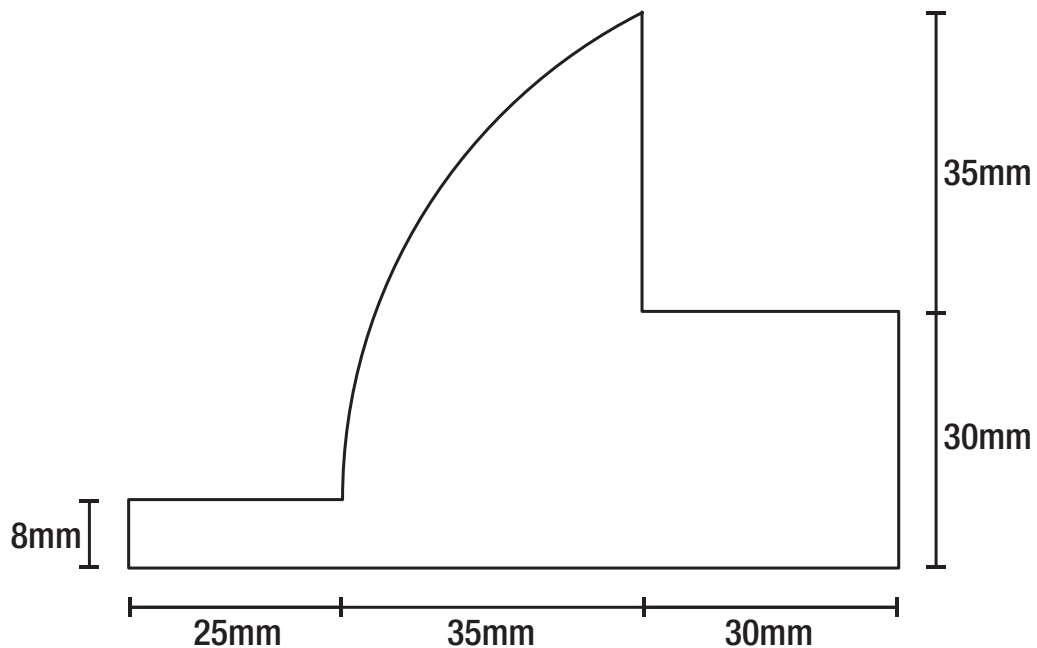

SYSTEM INSTALLATION

ABS PLASTIC MOUNTS

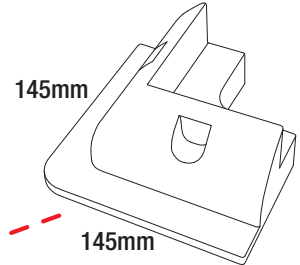
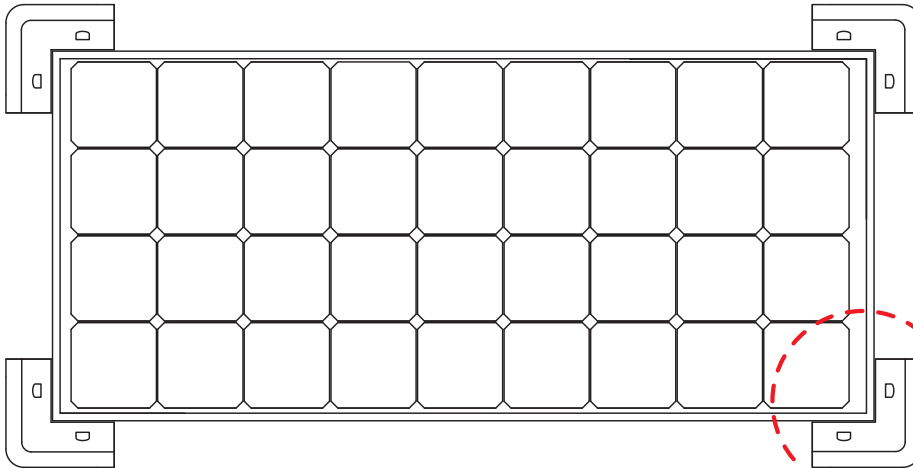

SMI9001
4 x ABS Plastic Corner
Mounts

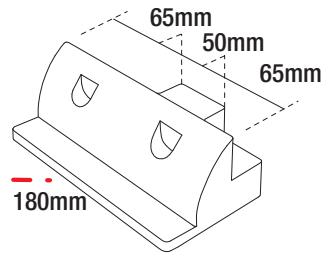
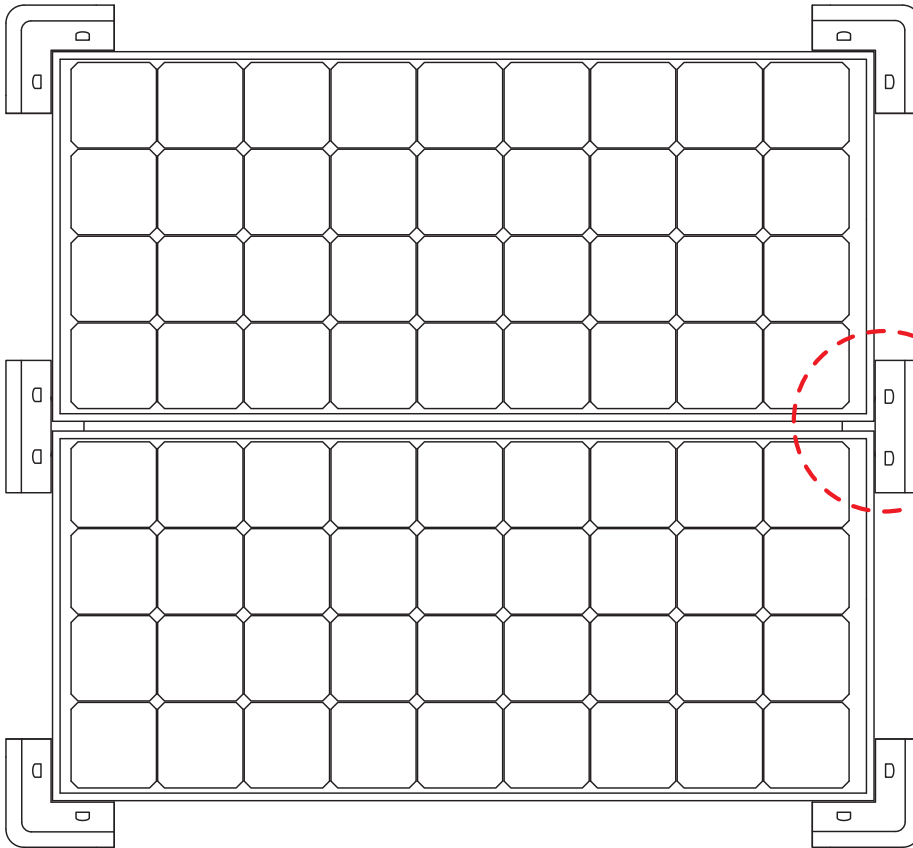

SMI9002
2 x ABS Plastic Side
Mounts
(for mounting multiple
panels)

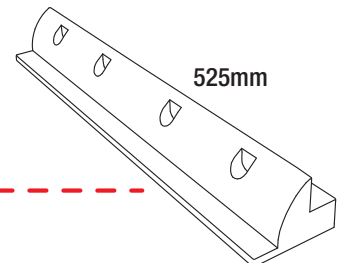
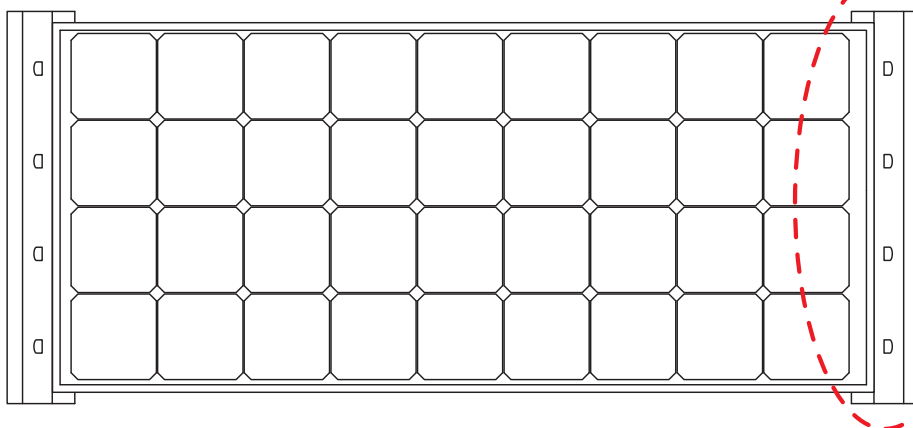

SMI9003
2 x ABS Plastic Spoiler
Mounts
(for lower wind
resistance)

SYSTEM INSTALLATION

CAUTION

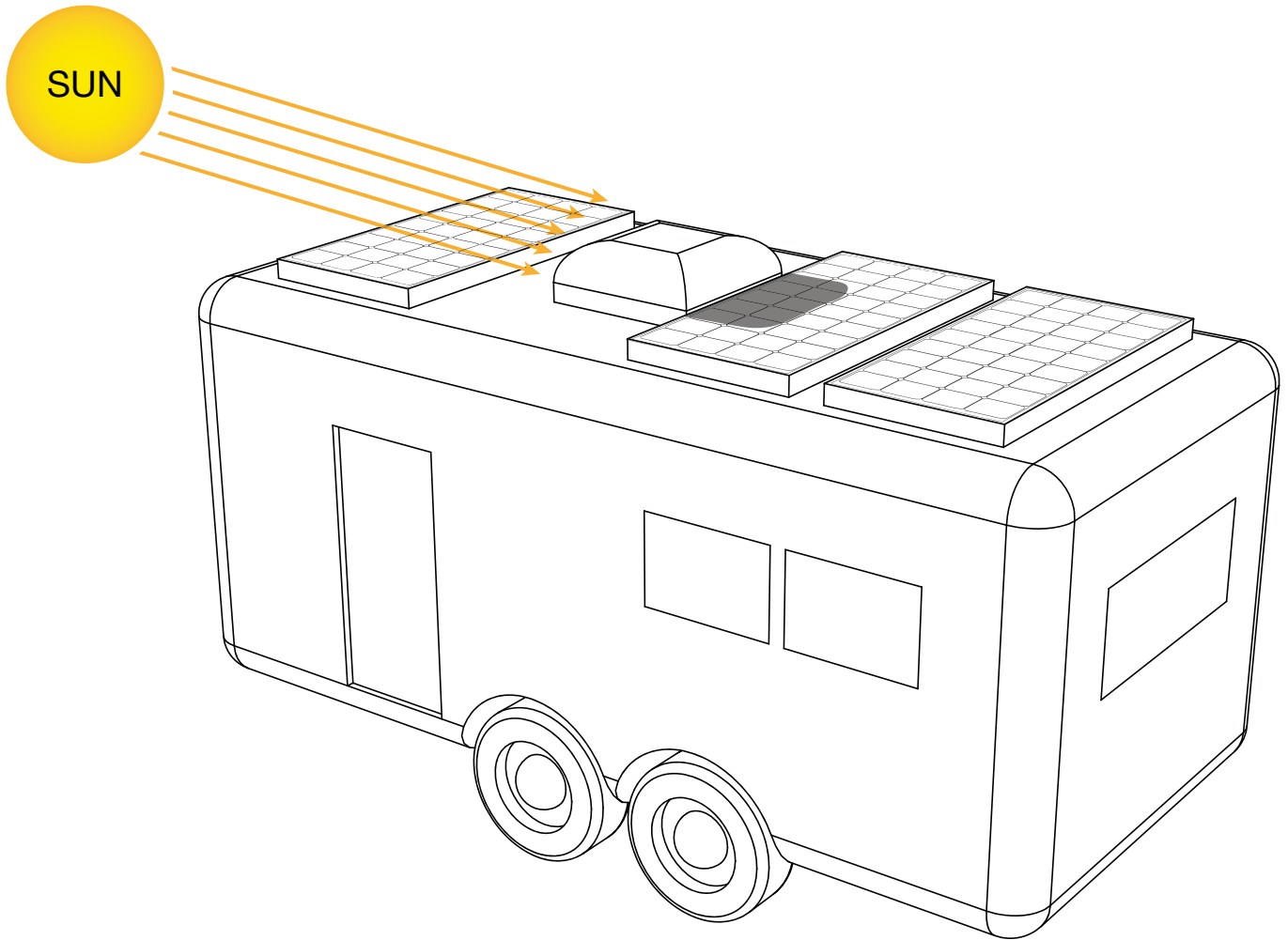

Be aware of shading that can occur as a result of roof mounted accessories on your caravan or motorhome. Shading sections of your solar panels will significantly reduce your solar panels performance. Care must be taken to avoid the possibility of shading as much as possible during the installation process.

The SMR1150-SL is specifically designed to offer an alternative where standard sized panels may not fit.

SYSTEM WIRING

WIRING MULTIPLE PANELS

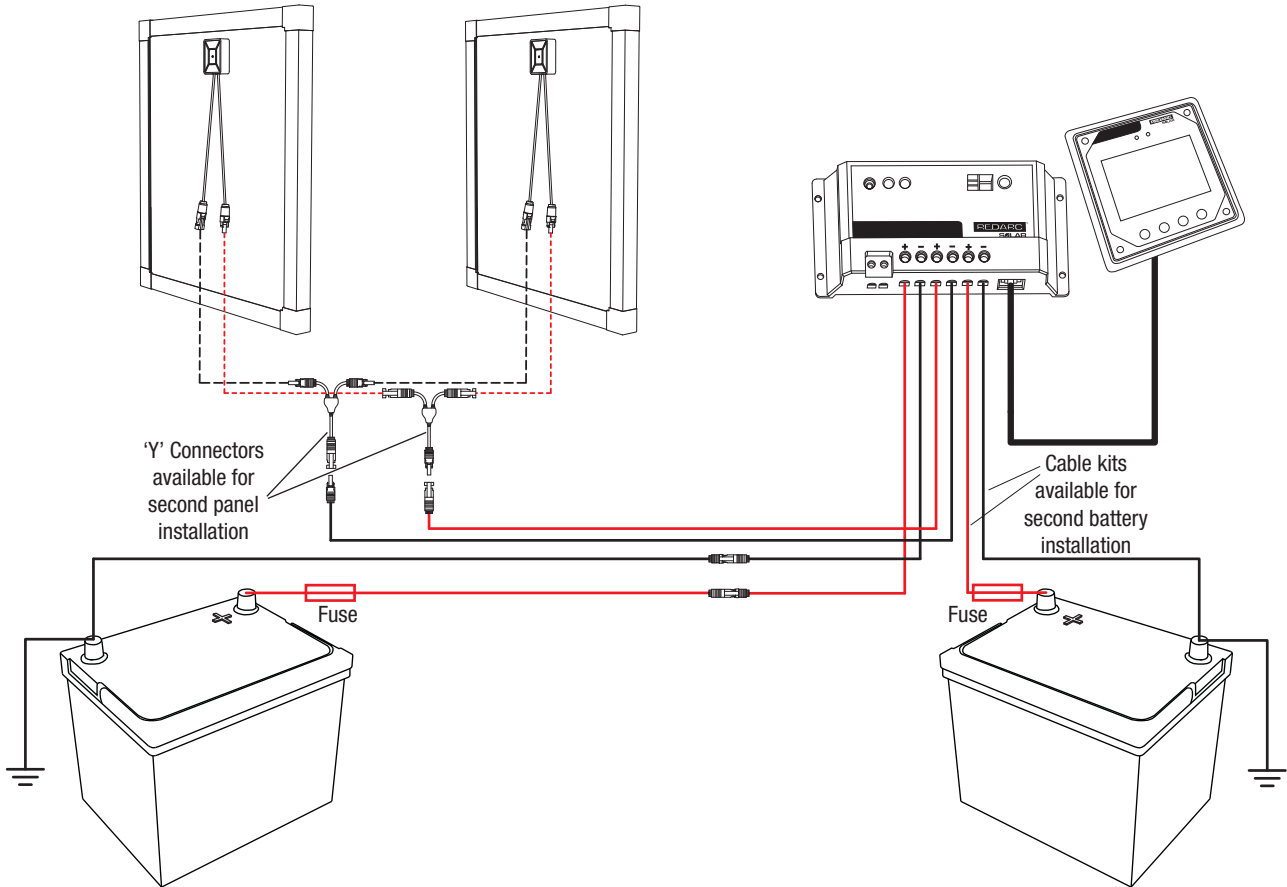

WIRING MULTIPLE PANELS OF DIFFERENT TYPES

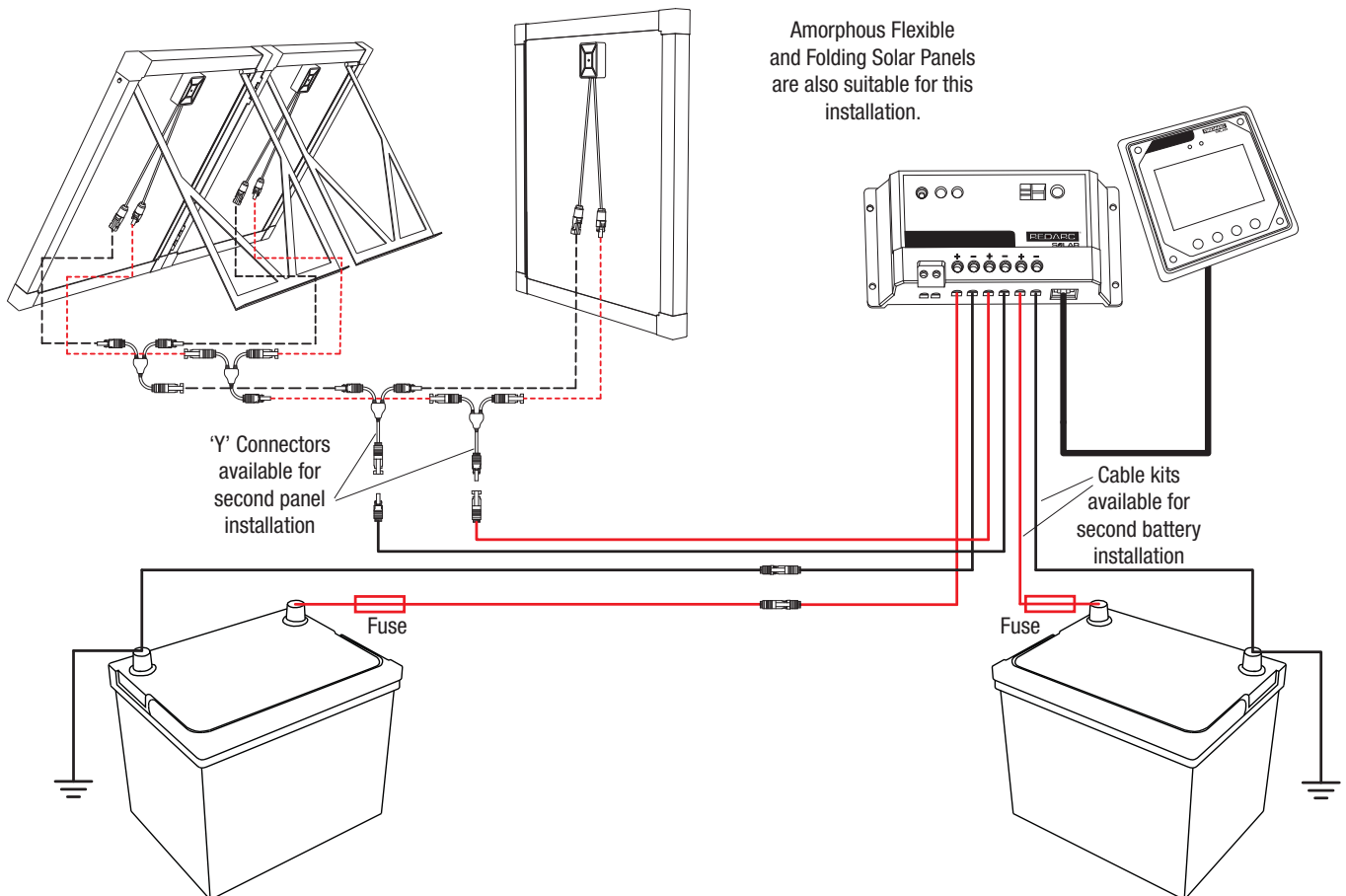

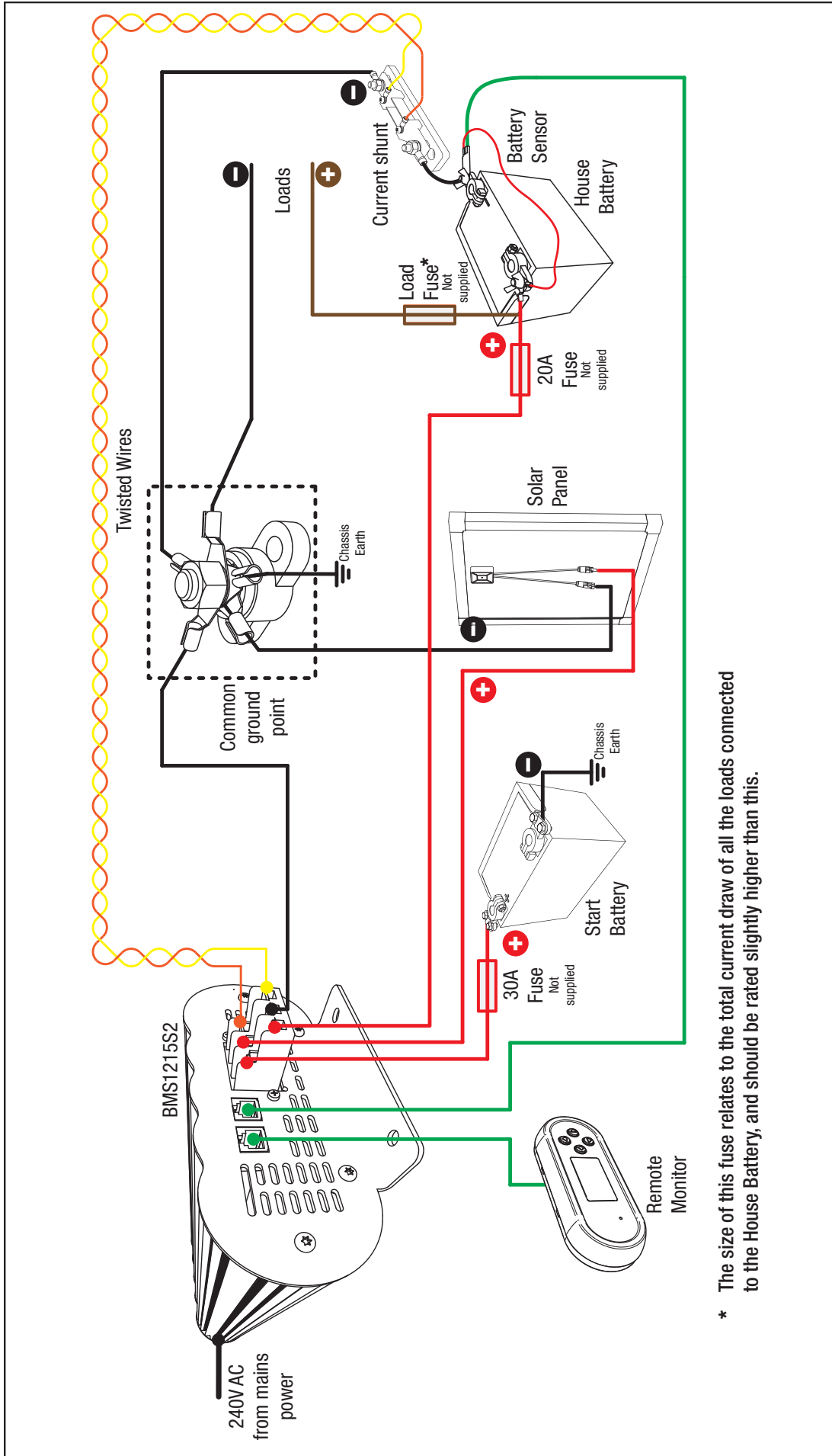

* The size of this fuse relates to the total current draw of all the loads connected to the House Battery, and should be rated slightly higher than this.

SYSTEM WIRING

WIRING PRECAUTIONS

- Ensure that all connections are made using REDARC recommended connectors and cables or other suitably rated connectors and cables.
- Ensure that total system current does not exceed the maximum current rating for either the cables or any connectors that are subject to the total current of the system.
- Ensure that grounding and fusing is adequate and sound for the system as per wiring diagrams on page 10.
- Ensure that all MC4 connections are crimped with the correct MC4 crimping tool. Contact REDARC for more information on purchasing this tool.
- All cable entries into the vehicle must be suitably sealed, REDARC Single or Double Cable Glands are recommended.
- If your regulator has a dedicated solar input ground (negative) terminal ensure that the negative ground from your solar panels is connected here.

PARALLEL AND SERIES CONNECTIONS

Solar arrays can be connected in Parallel or Series as per the diagrams below, or a combination of the two. Connecting two panels (same wattage) in parallel will multiply the total output current by 2 and keep the system voltage at the same level. Conversely, connecting two panels (same wattage) in series will multiply the system voltage by 2 and keep the output current at the same level. Parallel connections should be made using 'Y' connectors available through REDARC Solar suppliers. Series connections should be made by connecting the negative connector of one panel to the positive of the next.

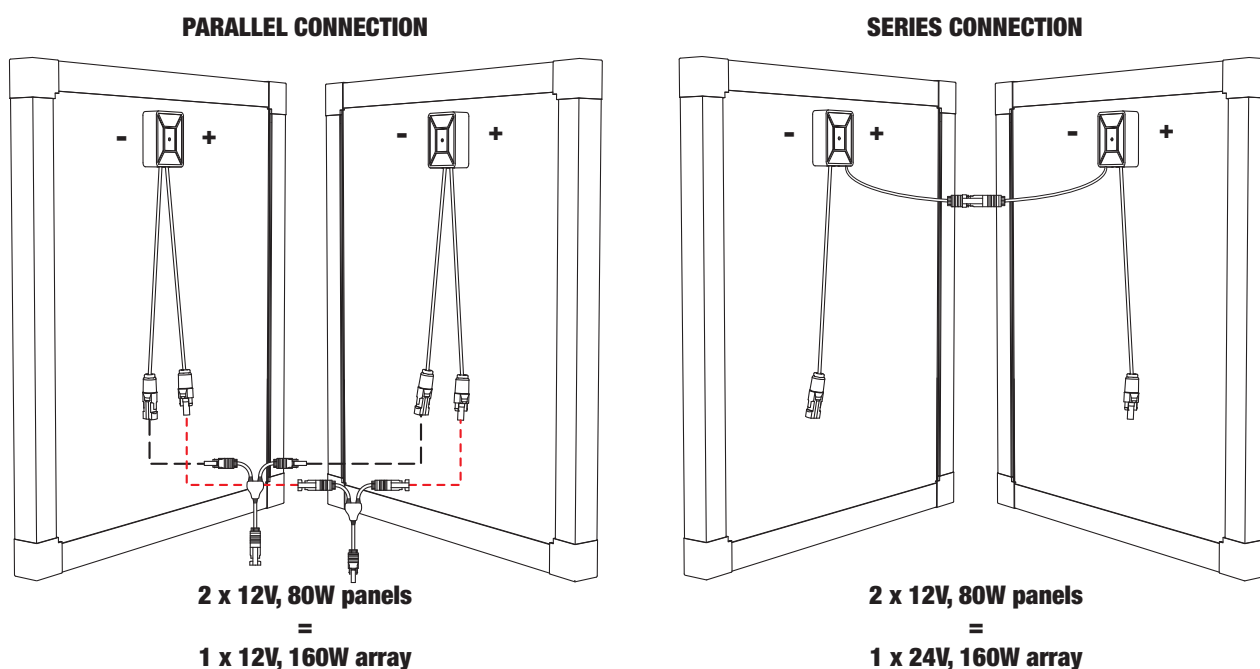

ACCESSORIES

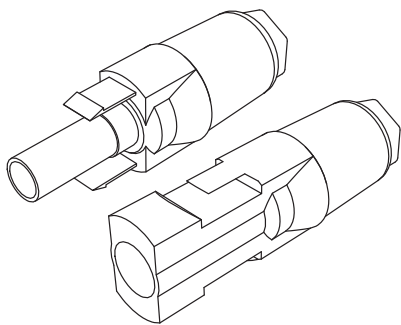

SRC0001-CK - MC4 CONNECTOR KIT

Comes with 1 x Male MC4 connector and crimp and 1 x Female MC4 connector and crimp.

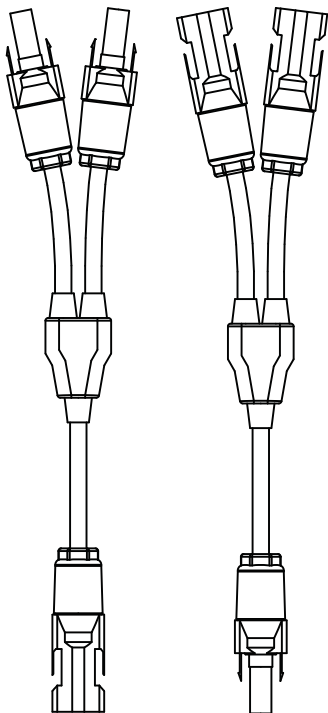

SRC0006 – MC4 ‘Y’ ADAPTOR KIT

- For connecting 2 positive and 2 negative MC4 connectors in parallel.
- Reduces the 2 outputs to 1 output.

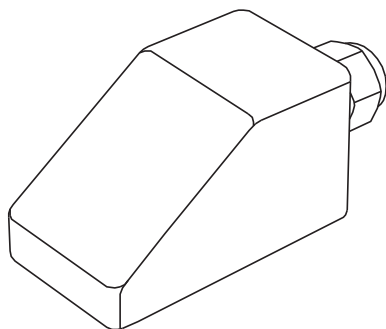

SMC0001 – SINGLE CABLE GLAND

For routing a single cable into your Caravan or RV. Use a suitable adhesive to seal the gland to the Caravan or RV and route the cable through the cable entry.

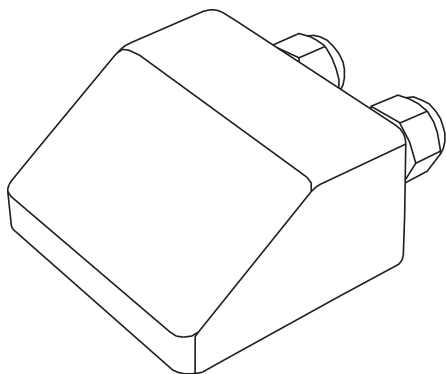

SMC0002 – DOUBLE CABLE GLAND

For routing multiple cables into your Caravan or RV. Use a suitable adhesive to seal the gland to the Caravan or RV and route the cable through the cable entry.

REDARC SOLAR PRODUCT WARRANTY

Over the last three decades our company has established a reputation as the power conversion specialist.

A 100% Australian-owned company, we have met the needs of customers in transport and other industries through exciting, innovative thinking.

We believe in total customer satisfaction and practice this by offering our customers:

- Technical advice free of jargon and free of charge
- Prompt turnaround of orders throughout Australia and globally
- Friendly, personalised, professional service and product support

In the unlikely event that a technical issue arises with a Redarc product, customers are encouraged to initially contact the Redarc Technical Support Team on (08) 8322 4848 or power@redarc.com.au for prompt and efficient diagnosis and product support.

Our goods come with guarantees that cannot be excluded under the Australian Consumer Law. You are entitled to a replacement or refund for a major failure and compensation for any other reasonably foreseeable loss or damage. You are also entitled to have the goods repaired or replaced if the goods fail to be of acceptable quality and the failure does not amount to a major failure.

The benefits of this Warranty are in addition to other rights and remedies available at law in respect of the Solar Products and shall not derogate from any applicable mandatory statutory provisions or rights under the Australian Consumer Law.

Redarc Electronics Pty Ltd atf the Redarc Trust trading as Redarc Solar ("**Redarc**") offers a warranty in respect of its Solar Products where the Solar Products are purchased from an authorised Redarc Solar distributor or reseller by a person ("**Purchaser**"), on the terms and conditions, and for the duration, outlined below in this document ("**Warranty**").

1. In this Warranty, the term **Solar Products** means:

- 1.1 Redarc Solar Monocrystalline Solar Panels;
 - 1.2 Redarc Solar Monocrystalline Folding Portable Solar Panel Kits;
 - 1.3 Redarc Solar Monocrystalline Folding Solar Panels;
 - 1.4 Redarc Solar Amorphous Flexible Solar Panels;
 - 1.5 Redarc Solar Amorphous Folding Solar Panels;
- (collectively the "**Modules**");
- 1.6 Redarc Solar Regulators and Displays;
 - 1.7 all other solar products manufactured or supplied by Redarc that are designed for use in recreational vehicles and boats, not otherwise specifically referred to in this clause 1; and
 - 1.8 any component of or accessory for any product in clause 1.1 to 1.7 (inclusive) manufactured or supplied by Redarc.

Offer and duration of product warranties

2. Subject to this clause 2, Redarc warrants that its Solar Products will be free, under normal application, installation, use and service conditions, from defects in materials and workmanship affecting normal use, for the relevant periods set out below:

- 2.1 Redarc Solar Monocrystalline Solar Panels – 5 years from the date of purchase;
- 2.2 Redarc Solar Monocrystalline Folding Portable Solar Panel Kits – 5 years from the date of purchase;
- 2.3 Redarc Solar Monocrystalline Folding Solar Panels – 2 year from the date of purchase;;
- 2.4 Redarc Solar Amorphous Flexible Solar Panels – 2 years from the date of purchase;
- 2.5 Redarc Solar Amorphous Folding Solar Panels – 2 years from the date of purchase;
- 2.6 Redarc Solar Regulators and Displays – 2 years from the date of purchase; and
- 2.7 all other Solar Products not otherwise set out in this clause 2 – 2 years from the date of purchase.

3. Where a Solar Product malfunctions (excluding as a result of a reduction in power output levels, which is the subject of clause 4) or becomes inoperative during the relevant warranty period applicable to that Solar Product pursuant to clause 2, due to a defect in materials or workmanship, as determined by Redarc, then subject to further rights conferred by the Australian Consumer Law on the Purchaser, Redarc will, in exercise of its sole discretion, either:

- 3.1 repair the defective Solar Product;
- 3.2 replace the defective Solar Product; or
- 3.3 provide a refund to the Purchaser for the purchase price paid for the defective Solar Product,

without charge to the Purchaser.

4. Redarc warrants that:

- 4.1 if any Redarc Solar Monocrystalline Solar Panels or any Redarc Solar Monocrystalline Folding Portable Solar Panel Kits exhibit a power output of less than 80% of Peak Power under Standard Test Conditions, within 25 years of the date of purchase;
- 4.2 if any Redarc Solar Monocrystalline Folding Solar Panels, Redarc Solar Amorphous Flexible Solar Panels or any Redarc Solar Amorphous Folding Solar Panels exhibit a power output of less than 80% of Peak Power under Standard Test Conditions, within 5 years of the date of purchase; and such loss of power is determined by Redarc to be due to a defect in materials or workmanship, then subject to further rights conferred by the Australian Consumer Law on the Purchaser, Redarc will, in exercise of its sole discretion, either:
 - 4.3 make up the loss in power by supplying the Purchaser with relevant additional Modules; or
 - 4.4 repair or replace the defective Modules, without charge to the Purchaser.

5. For the purposes of clause 4:

- 5.1 Peak Power means the minimum peak power level in Watts that a Module generates in its maximum power point (as stated on the label affixed to the Module or on the product information sheet accompanying the Module); and

5.2 **Standard Test Conditions** means:

- (a) light spectrum of AM 1.5;
- (b) an irradiation of 1,000 Watts per square metre; and
- (c) a cell temperature of 25 degrees centigrade at right angle irradiation,

the measurements being carried out in accordance with IEC61215 as tested at the connectors or junction box terminals (as applicable) per the calibration and testing standards of Redarc in effect on the date of manufacture of the Module.

6. The warranties given by Redarc in clauses 2 to 4 cover the reasonable costs of delivery and installation of any repaired or replaced Solar Products or components of Solar Products to the Purchaser's usual residential address notified to Redarc, together with the reasonable costs of removal and return of any Solar Products determined by Redarc to be defective.

7. If the Purchaser incurs expenses of the nature referred to in clause 6 in the context of making a claim pursuant to this Warranty that is accepted by Redarc, the Purchaser will be entitled to claim for reimbursement of those expenses which Redarc determines, in exercise of its sole

discretion, to be reasonably incurred, provided that the claim is notified to Redarc in writing at the postal address or email address specified in clause 23 and includes:

- 7.1 details of the relevant expenses incurred by the Purchaser; and
- 7.2 proof of the relevant expenses having been incurred by the Purchaser.

Exclusions and limitations

8. This Warranty will not apply to, or include any defect, damage, fault, failure or malfunction of a Solar Product, which Redarc determines to be due to:
 - 8.1 normal wear and tear or exposure to weather conditions over time;
 - 8.2 accident, misuse, abuse, negligence, vandalism, alteration or modification;
 - 8.3 non-observance of any of the instructions supplied by Redarc, including instructions concerning installation, configuring, connecting, commissioning, use or application of the Solar Product, including without limitation choice of location;
 - 8.4 failure to ensure proper maintenance of the Solar Product strictly in accordance with Redarc's instructions or failure to ensure proper maintenance of any associated equipment or machinery;
 - 8.5 repairs to the Solar Product that are not strictly in accordance with Redarc's instructions;
 - 8.6 installation, repairs or maintenance of the Solar Product by, or under the supervision of, a person who is not a qualified auto electrician or technician, or if non-genuine or non-approved parts have been fitted;
 - 8.7 faulty power supply, power failure, electrical spikes or surges, lightning, flood, storm, hail, extreme heat, fire or other occurrence outside the control of Redarc;
 - 8.8 use other than for any reasonable purpose for which the Solar Product was manufactured;
 - 8.9 any indirect or incidental damage of whatever nature outside the control of Redarc.
9. Warranty claims in respect of a Solar Product must be made in writing to Redarc at the postal address or email address specified in clause 23 within the relevant warranty period applicable to that Solar Product pursuant to clause 2 or clause 4. Such claims must include the following:
 - 9.1 details of the alleged defect or fault and the circumstances surrounding the defect or fault;
 - 9.2 evidence of the claim, including photographs of the Solar Product (where the subject of the claim is capable of being photographed);
 - 9.3 the serial number of the Solar Product, specified on the label affixed to the Solar Product; and
 - 9.4 proof of purchase documentation for the Solar Product from an authorised distributor or reseller of Redarc, which clearly shows the date and place of purchase.The return of any Solar Products without the prior written instructions of Redarc will not be accepted by Redarc.
10. Without limiting any other clause in this Warranty, Redarc has the right to reject any warranty claim made by a Purchaser pursuant to this Warranty where:
 - 10.1 the Purchaser does not notify Redarc in writing of a warranty claim within relevant warranty period applicable to that Solar Product;
 - 10.2 the Purchaser does not notify Redarc in writing of a warranty claim within 1 month of becoming aware of the relevant circumstances giving rise to the claim, so that any further problems with the Solar Product are minimised;
 - 10.3 the serial number of the Solar Product has been altered, removed or made illegible without the written authority of Redarc;
 - 10.4 the Purchaser is unable to provide proof of purchase documentation in accordance with clause 9.4 or evidence that the Solar Product was properly installed, and that proper maintenance has been performed on the Solar Product, by, or

under the supervision of, a qualified auto electrician or technician, in accordance with the instructions of Redarc.

11. If the Solar Product is found to be working satisfactorily on return to Redarc or upon investigation by Redarc, the Purchaser must pay Redarc's reasonable costs of testing and investigating the Solar Product in addition to shipping and transportation charges. Where Redarc is in possession of the Solar Product, the Solar Product will be returned to the Purchaser on receipt of the amount charged.
12. Any replaced Solar Products or components of Solar Products shall become the property of Redarc.
13. Redarc may, in exercise of its sole discretion, deliver another type of Solar Product or component of a Solar Product (different in size, colour, shape, weight, brand and/or other specifications) in fulfilling its obligations under this Warranty, in the event that Redarc has discontinued manufacturing or supplying the relevant Solar Product or component at the time of the warranty claim, or where such Solar Product or component is superior to that originally purchased by the Purchaser.

Other conditions of Warranty

14. If the Purchaser acquired a Solar Product for the purpose of resupply, then this Warranty shall not apply to that Solar Product.
15. In particular, the sale of a Solar Product via an online auction, online store or other internet website by a party that is not an authorised distributor or reseller of the Solar Product will be deemed to be a resupply within the meaning of the Australian Consumer Law and will render this Warranty void, as Redarc has no control over the storage, handling, quality or safety of Solar Products sold by such persons.
16. A Purchaser shall only be entitled to the benefit of this Warranty after all amounts owing in respect of the Solar Product have been paid.
17. While Redarc warrants that the Solar Products will be free from defects in materials and workmanship in the circumstances set out in this Warranty, to the maximum extent permitted by law Redarc does not warrant that the operation of the Solar Products will be uninterrupted or error-free.
18. To the maximum extent permitted by law, Redarc's determination of the existence of any defect and the cause of any defect will be conclusive.
19. Spare parts or materials for the Solar Products are guaranteed to be available for a period of at least 2 years after purchase of the Solar Products.
20. The agents, officers and employees of any distributor or reseller of the Solar Products and of Redarc are not authorised to vary or extend the terms of this Warranty.
21. Redarc shall not be responsible or liable to the Customer or any third party in connection with any non-performance or delay in performance of any terms and conditions of this Warranty, due to acts of God, war, riots, strikes, warlike conditions, plague or other epidemic, fire, flood, blizzard, hurricane, changes of public policies, terrorism and other events which are beyond the control of Redarc. In such circumstances, Redarc may suspend performance of this Warranty without liability for the period of the delay reasonably attributable to such causes.
22. If a clause or part of a clause in this Warranty can be read in a way that makes it illegal, unenforceable or invalid, but can also be read in a way that makes it legal, enforceable and valid, it must be read in the latter way. If any clause or part of a clause in this Warranty is illegal, unenforceable or invalid, that clause or part is to be treated as removed from this Warranty, but the rest of this Warranty is not affected.

Redarc's contact details

23. Redarc's contact details for the sending of warranty claims under the Warranty are:

Redarc Electronics Pty Ltd

23 Brodie Road (North), Lonsdale SA 5160

Email: power@redarc.com.au

Telephone: +61 8 8322 4848

AUSTRALIAN DESIGNED AND ENGINEERED

This product has been specified and tested in Australia in accordance with REDARC specifications and testing requirements by REDARC Engineers. You can be assured that this product meets the stringent quality levels of all REDARC products.



For free technical assistance please contact
Redarc Electronics
23 Brodie Road North, Lonsdale SA
(08) 8322 4848
power@redarc.com.au
www.redarcsolar.com.au

Copyright © 2011 Redarc Electronics Pty Ltd. All rights reserved.

This product is manufactured in China.